

A型钢制农机链

A type steel agricultural chains

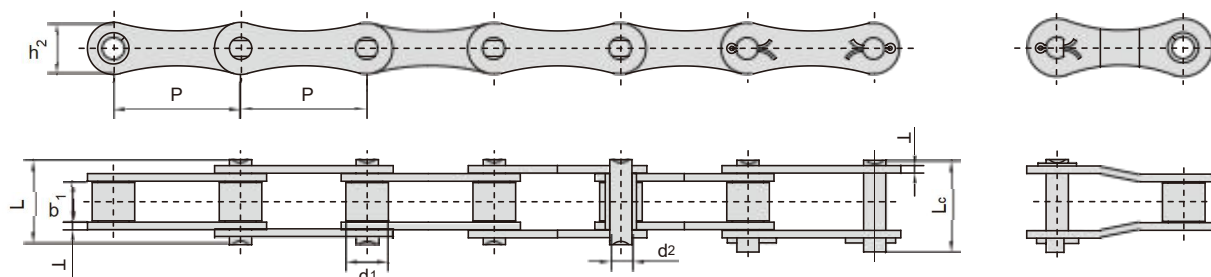

Hawkvine Chain No.	节距	滚子直径	内节内宽	销轴直径	销轴长度		链板尺寸		抗拉强度	平均抗拉强度	每米长重
	Pitch	Roller diameter	Width between inner plates	Pin diameter	Pin length		Plate dimension		Tensile strength	Average tensile strength	Weight per meter
	P	d1 max	b1 min	d2 max	L max	Lc max	h2 max	T max	Q min	Q0	q
	mm	mm	mm	mm	mm	mm	mm	mm	kN/lbf	kN	kg/m
A550	41.40	16.87	19.81	7.19	35.0	38.0	19.3	2.80	39.10/8886	51.2	1.79
A555	41.40	16.87	12.70	7.19	29.1	32.0	19.3	3.10	39.10/8886	56.0	1.60
A557	41.40	17.78	20.24	8.00	37.4	40.6	23.1	3.10	55.61/12639	74.3	2.45
A620	42.01	17.91	24.51	7.19	41.8	45.2	20.2	3.25	39.10/8886	55.1	2.18

CA型钢制农机链

CA type steel agricultural chains

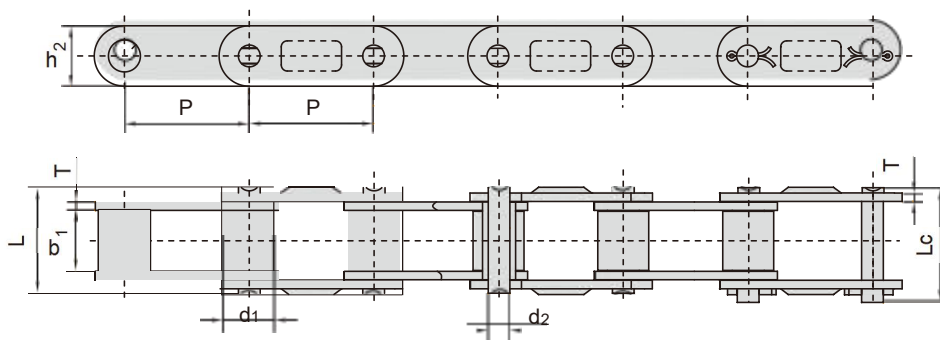

Hawkvine Chain No.	节距	滚子直径	内节内宽	销轴直径	销轴长度		链板尺寸		抗拉强度	平均抗拉强度	每米长重
	Pitch	Roller diameter	Width between inner plates	Pin diameter	Pin length		Plate dimension		Tensile strength	Average tensile strength	Weight per meter
	P	d1 max	b1 min	d2 max	L max	Lc max	h2 max	T max	Q min	Q0	q
	mm	mm	mm	mm	mm	mm	mm	mm	kN/lbf	kN	kg/m
CA627	30.00	15.88	19.05	8.28	36.1	39.4	20.5	3.00	50.00/11247	55.0	2.51
CA550D	41.40	16.87	19.81	7.19	35.0	38.0	19.3	2.80	39.10/8886	51.2	1.94
CA555D	41.40	16.87	12.70	7.19	29.1	32.0	19.3	3.10	39.10/8886	56.0	1.72
CA557D	41.40	17.78	20.24	8.00	37.4	40.6	23.1	3.10	55.61/12639	74.3	2.60
CA620D	42.01	17.91	24.51	7.19	41.8	45.2	20.2	3.25	39.10/8886	55.1	2.35
CA2062H	38.10	22.23	12.57	5.94	29.2	31.6	18.0	3.25	31.10/6992	35.0	2.30
CA627F1	30.00	15.88	19.60	8.28	36.1	39.7	20.5	3.00	50.00/11241	55.0	2.55

CA型钢制农机链

CA type steel agricultural chains

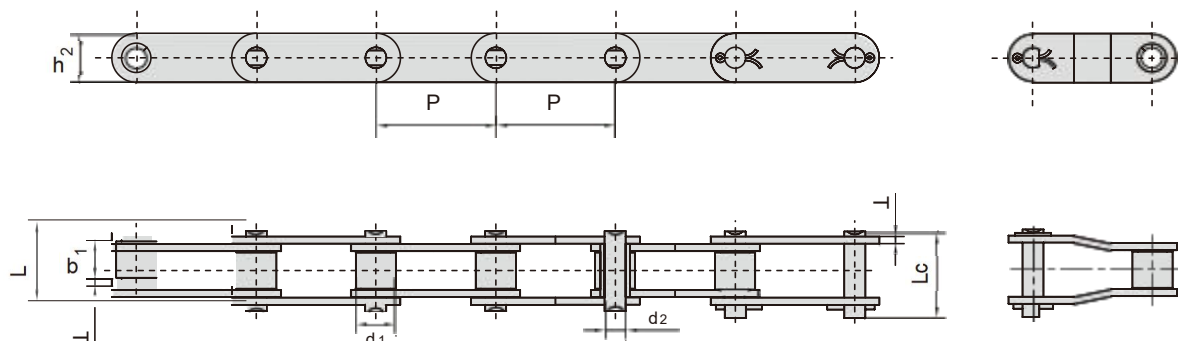

Hawkvine Chain No.	节距	滚子直径	内节内宽	销轴直径	销轴长度		链板尺寸		抗拉强度	平均抗拉强度	每米长重
	Pitch	Roller diameter	Width between inner plates	Pin diameter	L	Lc	h2	T	Tensile strength	Average tensile strength	Weight per meter
	P mm	d1 max mm	b1 min mm	d2 max mm	L max mm	Lc max mm	h2 max mm	T max mm	Q min kN/lbf	Q0 kN	q kg/m
38.4R	38.400	15.88	19.05	6.92	33.8	36.4	17.30	2.50	33.00/7480	41.2	1.70
38.4V	38.400	15.88	18.00	6.92	35.0	38.0	17.30	3.00	40.00/9091	50.0	1.83
38.4VB	38.400	15.88	19.05	8.28	36.1	39.4	20.50	3.00	50.00/11363	62.5	2.17
55VD	41.400	17.90	23.00	8.22	39.3	42.4	20.00	2.80	42.00/9546	45.0	2.34
CA2060H	38.100	11.91	12.70	5.94	29.2	31.6	18.00	3.25	31.10/6996	40.5	1.45
CA550	41.400	16.87	19.81	7.19	35.0	38.0	19.30	2.80	39.10/8886	51.2	1.94
CA550(U)	41.400	16.86	19.80	7.19	35.5	28.3	19.50	2.80	48.91/10996	53.8	1.98
CA550F4	41.400	14.35	20.24	7.14	35.0	38.5	19.05	2.80	50.00/11363	52.0	1.76
CA550F5	41.400	16.66	20.24	7.14	35.0	38.5	19.05	2.80	45.00/10227	52.0	1.97
CA550H	41.400	16.74	20.00	7.14	36.0	39.1	19.10	3.00	57.82/13000	60.8	2.00
CA550V	41.400	16.80	19.05	8.28	36.1	39.1	22.00	3.00	55.00/12499	68.7	2.24
CA550VF2	41.400	16.80	19.05	8.28	36.1	38.8	20.00	3.00	55.00/12499	68.7	2.13
CA555	41.400	16.87	12.70	7.19	29.1	32.0	19.30	3.10	39.10/8886	56.0	1.72
CA557	41.400	17.78	20.24	8.00	37.4	40.6	23.10	3.10	55.61/12639	74.3	2.60
CA557(U)	41.400	17.78	19.50	8.00	37.5	40.6	23.30	3.10	64.50/14501	71.0	2.55
CA620	42.010	17.91	24.51	7.19	41.8	45.2	20.20	3.25	39.10/8886	55.1	2.35
CA960	41.400	17.78	22.61	8.90	40.1	43.0	23.10	3.00	66.00/15160	72.6	6.94
CAE44151	28.575	15.88	16.20	7.92	33.5	36.9	22.20	3.25	58.80/13363	64.5	2.73
S62F3	41.910	19.05	25.40	8.00	42.0	44.6	26.00	3.00	47.00/10796	58.7	3.12